



PRODUCT GUIDE







ABOUT US

NZ owned and operated, MAXRaft specialises in fully insulated concrete foundation products. MAXRaft products deliver excellent thermal performance and energy efficiency for a range of projects from the foundation up – from schools, hospitals and retirement villages, to social housing developments and stand-alone residential homes.

MAXRaft offer products designed to suit different ground conditions. All MAXRaft products feature pre-cut polystyrene components which are manufactured off-site. All MAXRaft products are supplied with a panel plan to maximise on-site efficiency and minimise waste. Each component contains up to 15% recycled material and can be recycled at end of life.

MAXRaft products are suitable for Homestar and Passive House designs and have exceeded the building code requirements for over ten years, making them a reliable solution for easily meeting compliance and significantly reducing heat loss through the foundation.

The R-values achieved with MAXRaft products are dependent on project-specific design and area to perimeter ratio. All MAXRaft products can also work in conjunction with Underfloor Heating where a minimum of R3* is required.

This guide will outline the suitable MAXRaft products for the building code requirements.

*See underfloor heating information



UPDATE FROM MAXRAFT FEBRUARY 2024

We have made some exciting changes to the latest version of the Product Guide.

Hold Down Fixings

Last year, in conjunction with BRANZ, we completed testing with a straight hold down fixing and 90mm frame. We have updated the MAXEdge standard details for each of our products to reflect this new detail. This allows the use of either the Bowmac Blue Head Anchors or Hilti HUS-4 with capsule.

Our old MAXEdge perimeter details for 90mm frame remain and will achieve slightly higher R-values, however they are now alternative details and can be used in conjunction with an angled hold down fixing. See more here Hold Down Fixings (maxraft.co.nz)

You can download the test report here:

Downloads (maxraft.co.nz).

Pre-coated MAXEdge Insulation

Our MAXEdge perimeter insulation can now come to site either:

- Pre-coated with a waterproof 2mm thick resin, painting is recommended, but not essential.
- Uncoated, the slab is typically rendered after the concrete pour with a plaster system or a hard-edge board is applied.

You can see more information on MAXEdge Finishing via our website www.maxraft.co.nz.

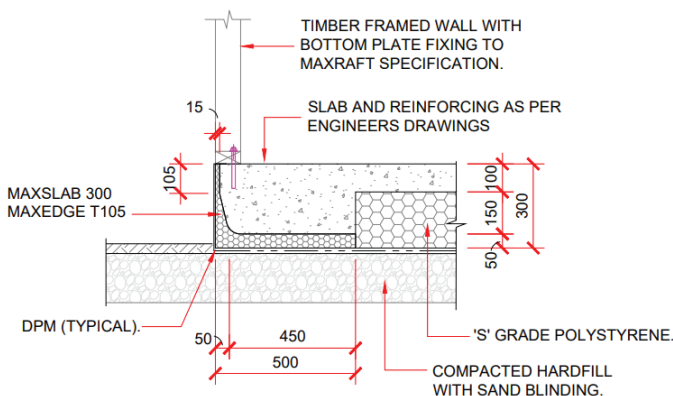
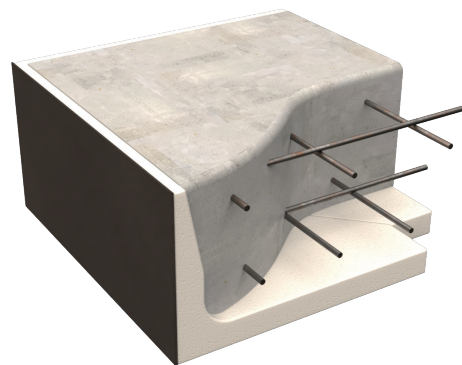

EXTERNAL FOOTING DETAIL
MAXEDGE T105 - 90mm FRAMING

CONTENTS

H1 Compliance	6
Zone Map	7
PRODUCTS	9
MAXEdge	10
MAXSlab	12
MAX85	14
MAXRaft	16
MAXRaft Plus+	18
MAXRaft Engineering	20
MAXRaft with Underfloor Heating	21
Sustainability and Recycling	22
Summary R-Value Table	23

COMPLIANCE H1 INFORMATION

The new standards are set depending on building type. All residential (including apartments and wharenui) and other buildings under 300m² of lettable area refer to Table 1. For any non-residential buildings under 300m² that are not industrial warehouse or hangers, the new standards are reflected in Table 2.

H1/AS1 For all Residential and commercial buildings under 300m²

Table 2.1.2.2B: Minimum construction R-values for building elements that do not contain embedded heating systems
Paragraphs 2.1.2.2 b), 2.1.3.1







Construction R-values (m ² K/W) ⁽¹⁾						
Building element	Climate Zone 1	Climate Zone 2	Climate Zone 3	Climate Zone 4	Climate Zone 5	Climate Zone 6
Roof ⁽²⁾	R6.6	R6.6	R6.6	R6.6	R6.6	R6.6
Wall	R2.0	R2.0	R2.0	R2.0	R2.0	R2.0
Floor slab-on-ground floors	R1.5	R1.5	R1.5	R1.5	R1.6	R1.7
Floors other than slab-on-ground floors	R2.5	R2.5	R2.5	R2.8	R3.0	R3.0
Windows and doors ⁽³⁾	R0.46 ⁽³⁾	R0.46 ⁽³⁾	R0.46	R0.46	R0.50	R0.50
Skylights	R0.46	R0.46	R0.54	R0.54	R0.60	R0.60

H1/AS2 For all Non-Residential buildings with over 300m² lettable floor area

Table 2.1.2.2B: Minimum construction R-values for building elements that do not contain embedded heating systems
Paragraphs 2.1.2.2 b), 2.1.3.1

Construction R-values (m ² K/W) ⁽¹⁾						
Building element	Climate Zone 1	Climate Zone 2	Climate Zone 3	Climate Zone 4	Climate Zone 5	Climate Zone 6
Roof ⁽²⁾	R3.5	R4.0	R5.0	R5.4	R6.0	R7.0
Wall	R2.2	R2.4	R2.7	R3.0	R3.0	R3.2
Floor	R2.2	R2.2	R2.2	R2.4	R2.5	R2.6
Windows and doors	R0.33	R0.33	R0.37	R0.37	R0.40	R0.42
Skylights	R0.42	R0.42	R0.46	R0.46	R0.49	R0.51

CLIMATE ZONE MAP

		Heated	Unheated
Climate zone 1		2.5	1.5
Climate zone 2		2.5	1.5
Climate zone 3		2.5	1.5
Climate zone 4		2.8	1.5
Climate zone 5		3.0	1.6
Climate zone 6		3.0	1.7

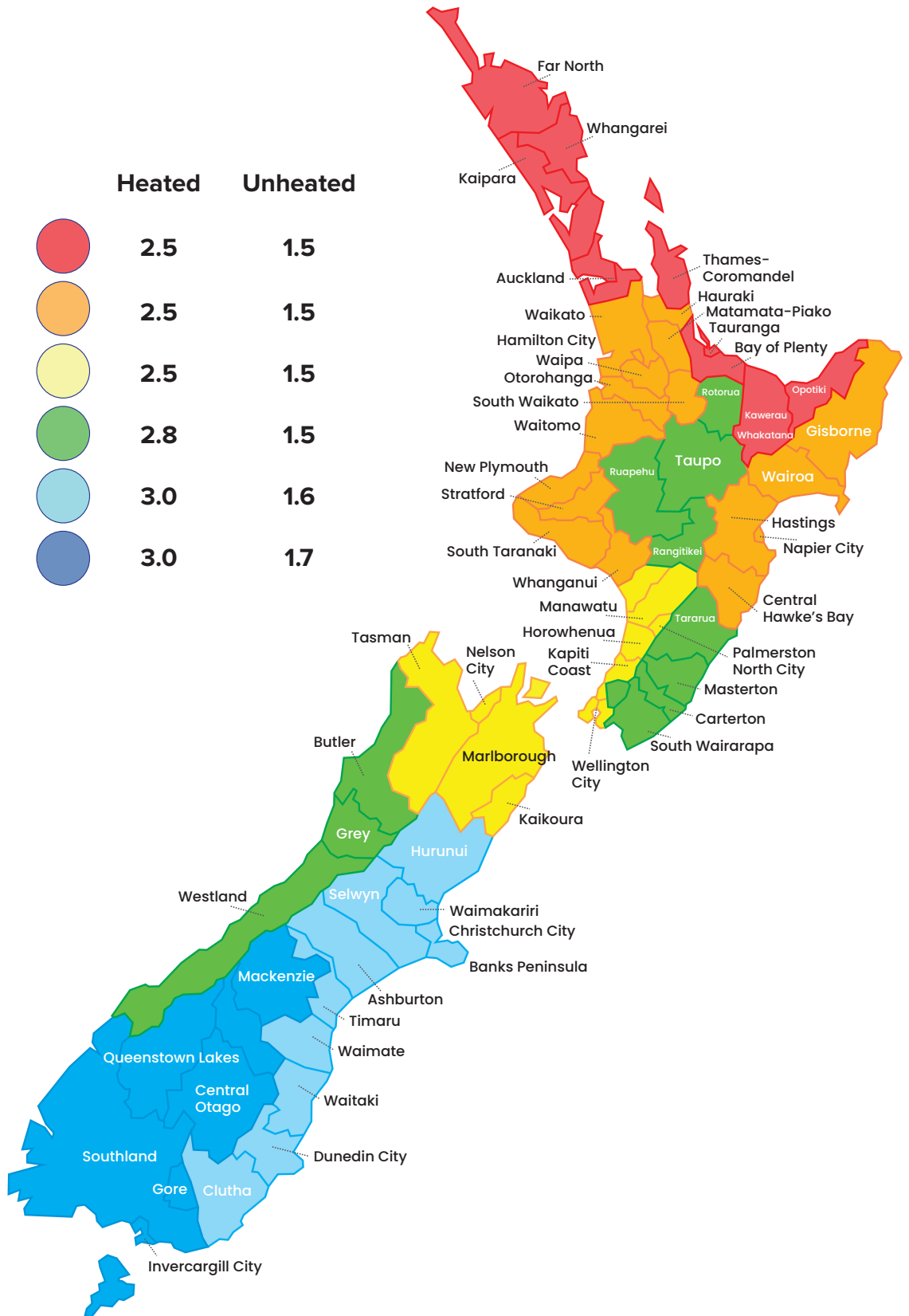



PRODUCTS

MAXRaft offers three fully insulated foundation products to meet different ground conditions and insulation requirements.

 **MAXEdge**[®]

 **MAXSlab**[®]

 **MAX85**[®]

 **MAXRaft**[®]

 **MAXRaft**[®]PLUS+

Each product can include:

1. **MAXEdge** L Shape profiles which reduce heat loss from the perimeter.
2. **VH EPS** Load bearing thickenings or ribs
3. **Polystyrene infill or pods** (The grade of EPS differs depending on product)

MAXRaft is BRANZ appraised.

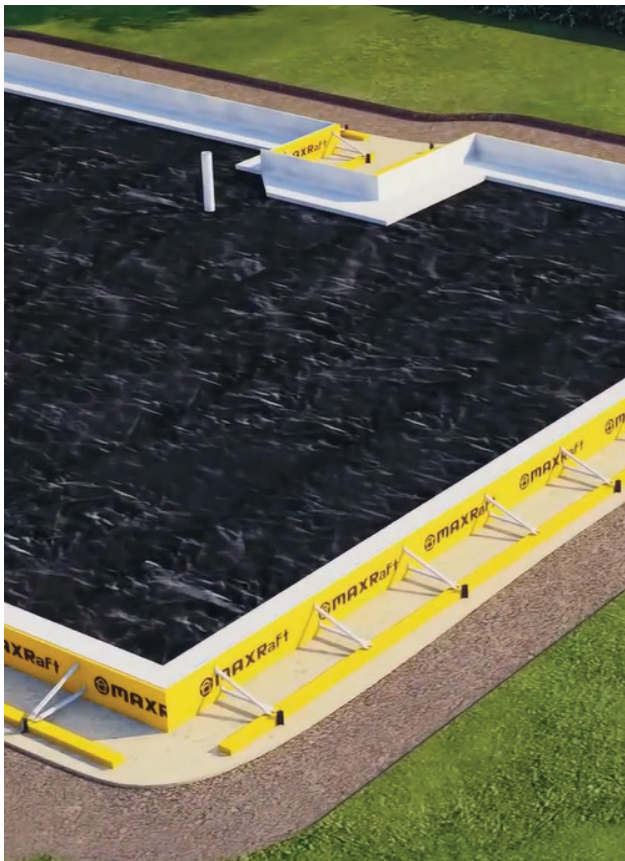
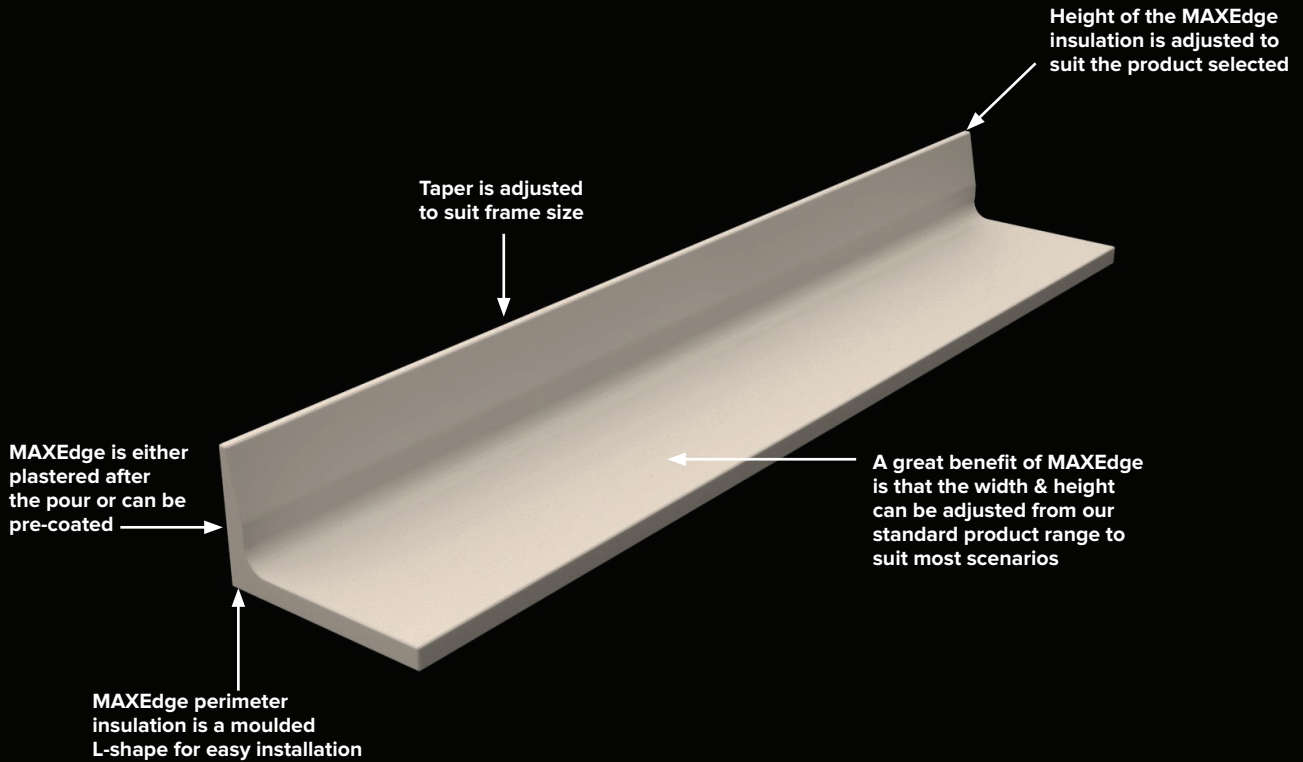

PRODUCT INFORMATION

MAXEdge is an innovative and patented L-shaped slab edge insulation that is a vital component of all our products.

MAXEdge is greater than R1 edge insulation and can be used in conjunction with the H1 AS1 tables for all wall types.

Our MAXEdge profiles are designed to be easily installed inside the formwork and can be adjusted to suit different projects.

By using MAXEdge, you can ensure that your building is equipped with superior insulation that not only provides optimal thermal performance, but also easily surpass the requirements of the New Zealand Building Code.

GENERAL INFORMATION

The MAXEdge perimeter insulation requires physical protection and protection from UV rays and waterproofing.

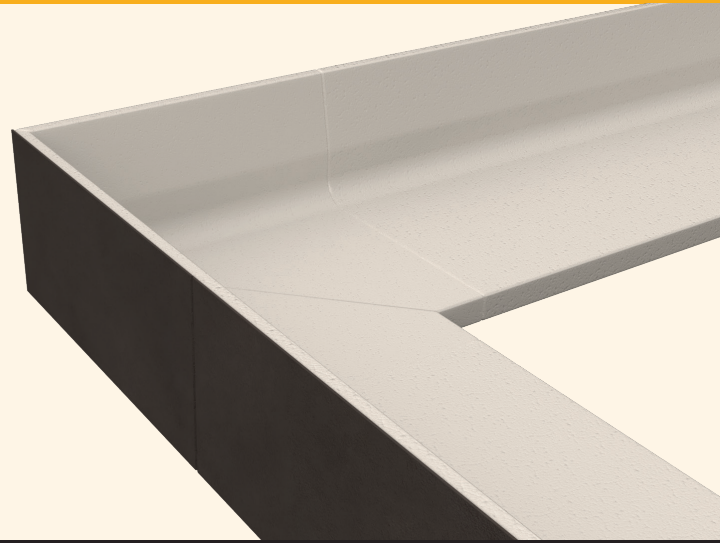

OPTIONS INCLUDE:

OPTION 1

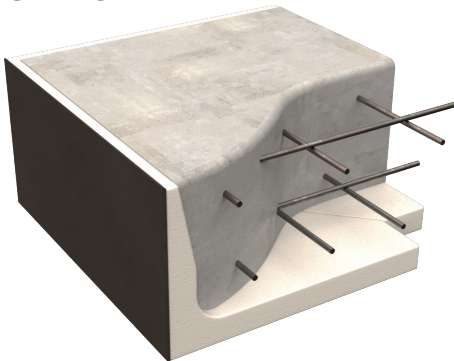

Pre-coated MAXEdge[®]

MAXEdge insulation arrives to site pre-coated and simply requires painting during the build process.

MAXEdge precoat is both UV Resistant and waterproof. Although not required, painting is recommended for a more modern finish.

OPTION 2

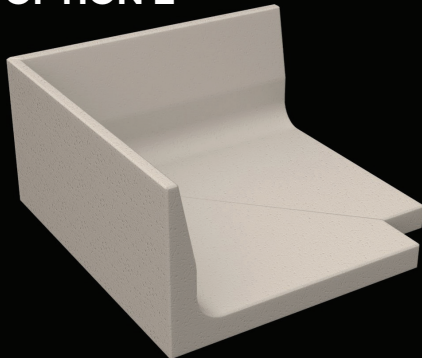

Plastering clean MAXEdge[®]

MAXRaft has plastering contacts nationwide or you can engage your chosen plasterer.

For more information see our website www.maxraft.co.nz/resources/plasterers

MAXEdge[®] KAPO BOARD

MAXRaft[®] has an exclusive relationship with Envirosquare and their KAPO Board on MAXEdge insulated foundations. The KAPO Board is appraised for use as a coating option on MAXRaft[®] for both EPS and XPS.

For more information visit: www.envirosquare.com



PRODUCT INFORMATION

MAXSlab is designed for TC1/ good ground found in many places in New Zealand.

KEY FEATURES

- Superior R-values
- VH EPS perimeter & thickening insulation
- Solid sheets of insulation under slab (no ribs)
- Suitable with 90mm/140mm/SIPS
- Suitable with UF Heating
- Panel plan and pre-cut materials
- Minimum waste / Recycled polystyrene material
- Engineered design
- Suitable for sloping sites

DETAIL

VH EPS, VH Thickenings, S Grade sheets.

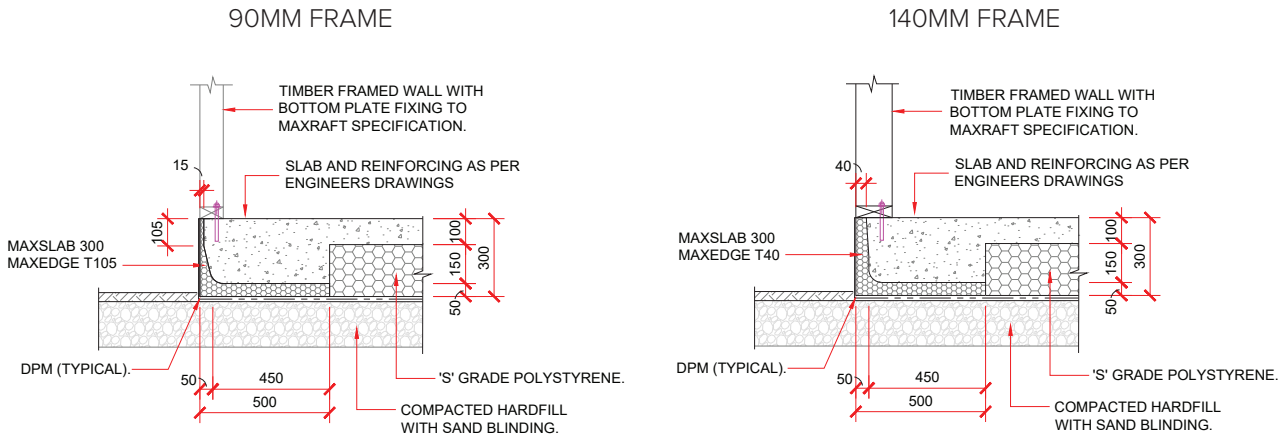

STANDARD HEIGHTS

300MM	350MM	400MM
--------------	--------------	--------------

Bespoke options available

R VALUE TABLE

	AREA / PERIMETER RATIO									
	1.6	1.8	2	2.2	2.4	2.6	2.8	3	3.6	4
MAXSlab 300	2.42	2.64	2.85	3.01	3.17	3.32	3.48	3.64	4.03	4.28
MAXSlab 350	2.96	3.25	3.53	3.69	3.85	4.01	4.17	4.33	4.87	5.23
MAXSlab 400	2.89	3.17	3.45	3.65	3.84	4.04	4.23	4.43	4.92	5.25
MAXSlab 300 Brick* Rebate	2.27	2.48	2.68	2.83	2.99	3.14	3.29	3.44	3.95	4.29

- * If brick cladding is to ground, please refer to the MAXSlab or MAXRaft R-Value details shown in above table. (Non-brick)
- * alternative MAXEdge 90mm details available with angled bolt fixing.
- * R-values are conservative and based on 90mm frames



PRODUCT INFORMATION

MAX85 is designed to meet the minimum H1 building code requirements.

Unlike the MAXSlab or MAXRaft products, MAX85 does not have insulation in thickenings and ribs.

KEY FEATURES

- Includes MAXRaft patent VH EPS Perimeter
- Suitable for good ground/ soft ground / TC2/ expansive soils/ piles
- Suitable with 90mm/140/SIPS
- Panel plan and pre cut materials
- Engineered design
- 85mm concrete
- Suitable for sloping sites

*See Area/ perimeter table on right hand page.

DETAIL

VH EPS MAXRaft Perimeter, Standard waffle pods

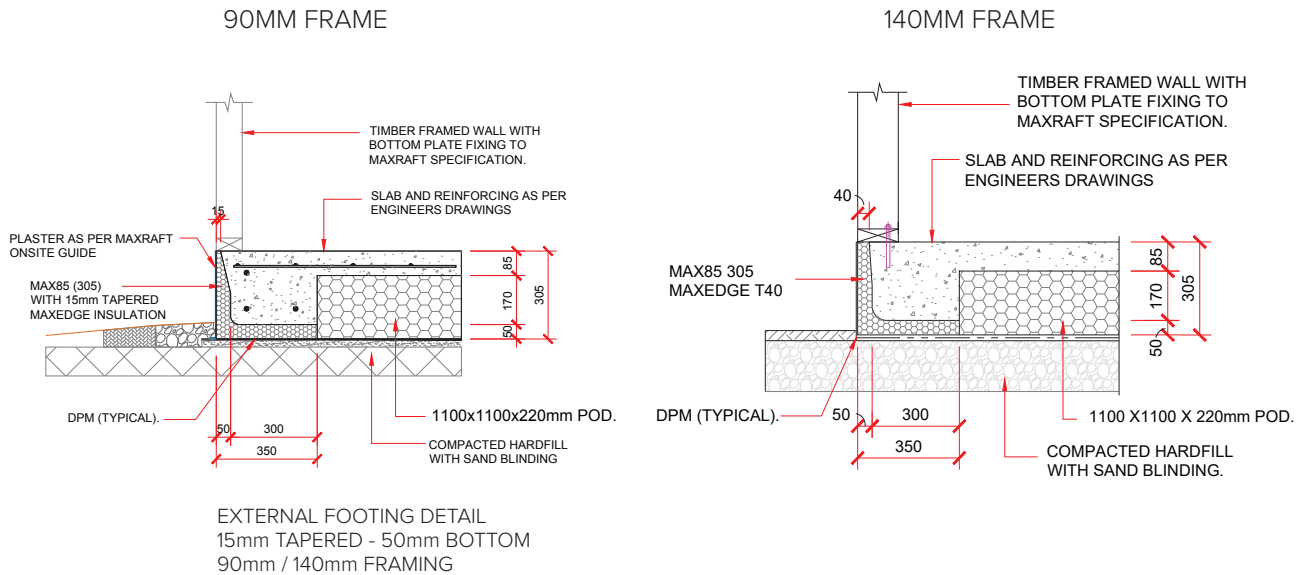

305MM	320MM	385MM	400MM
--------------	--------------	--------------	--------------

Bespoke options available

R VALUE TABLE

	AREA / PERIMETER RATIO									
	1.6	1.8	2	2.2	2.4	2.6	2.8	3	3.6	4
MAX85 305	1.46	1.54	1.62	1.7	1.77	1.85	1.92	2	2.21	2.36
MAX85 385	1.52	1.62	1.72	1.8	1.88	1.96	2.03	2.11	2.33	2.48
MAX85 305 Brick	1.3	1.39	1.47	1.55	1.62	1.7	1.78	1.85	2.06	2.21
MAX85 385 Brick	1.34	1.43	1.53	1.6	1.68	1.76	1.84	1.92	2.14	2.28

* alternative MAXEdge 90mm details available with angled bolt fixing.

* R-values are conservative and based on 90mm frames

* Angled bolt fixings are required to achieve 90mm framing R-Values shown in table. Please contact MAXRaft for R-Values when using a straight bolt fixing.



MAXRaft®

200KPA / TC2 / EXPANSIVE SOILS / PILES



PRODUCT INFORMATION

MAXRaft slabs are typically designed on soft ground, 200KPA / TC2 / Expansive soils / Piles

KEY FEATURES

- VH EPS perimeter & thickening insulation
- Easily meets the building code
- Suitable with 90mm/140mm/SIPS
- Panel plan and pre-cut materials including- PODS
- Minimum waste / Recycled polystyrene materials Engineered design

DETAIL

VH EPS Profile, VH EPS Ribs & Thickenings, standard eps waffle pods.

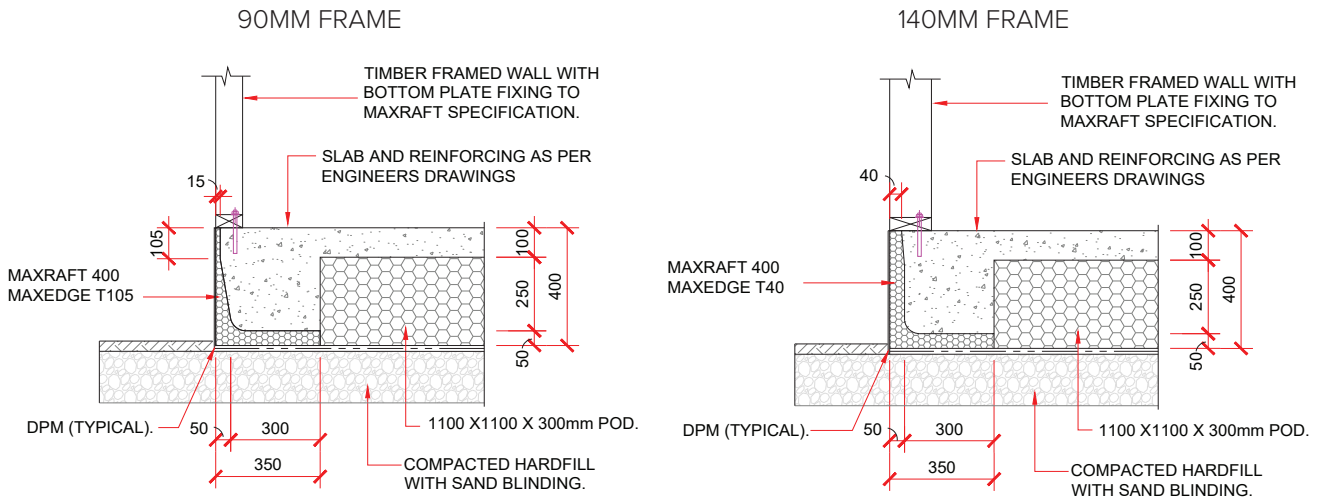

STANDARD HEIGHTS

320MM	340MM	400MM	420MM
--------------	--------------	--------------	--------------

Bespoke options available

R VALUE TABLE

	AREA / PERIMETER RATIO									
	1.6	1.8	2	2.2	2.4	2.6	2.8	3	3.6	4
MAXRaft 320	1.71	1.82	1.92	2.01	2.09	2.18	2.27	2.35	2.59	2.75
MAXRaft 400	1.68	1.81	1.93	2.01	2.1	2.18	2.27	2.35	2.59	2.74
MAXRaft 400	1.57	1.67	1.77	1.86	1.94	2.03	2.11	2.19	2.43	2.58
MAXRaft 320 Brick*	1.62	1.73	1.85	1.93	2.02	2.11	2.2	2.29	2.53	2.69
MAXRaft 400 Brick*	1.56	1.68	1.79	1.87	1.96	2.05	2.14	2.23	2.46	2.62

* If brick cladding is to ground, please refer to the MAXSlab or MAXRaft R-Value details shown in above table. (Non-brick)
 * alternative MAXEdge 90mm details available with angled bolt fixing.
 * R-values are conservative and based on 90mm frames



PRODUCT INFORMATION

MAXRaft Plus+ is designed to achieve better performance than a standard MAXRaft. It utilises solid PODS instead of typical waffle pods to achieve higher R-values. MAXRaft Plus+ is a great option where UF heating is specified on soft ground conditions.

KEY FEATURES

- Solid insulation throughout
- Easily meets the building code
- Suitable with 90mm/140mm/SIPS
- VH EPS perimeter & thickening insulation
- Panel plan and pre-cut materials including PODS
- Minimum waste / Recycled polystyrene materials
- 50/50 recycled pods or S grade solid pods

DETAIL

VH EPS Profile, VH EPS Ribs & Thickenings, standard eps Solid Pods.

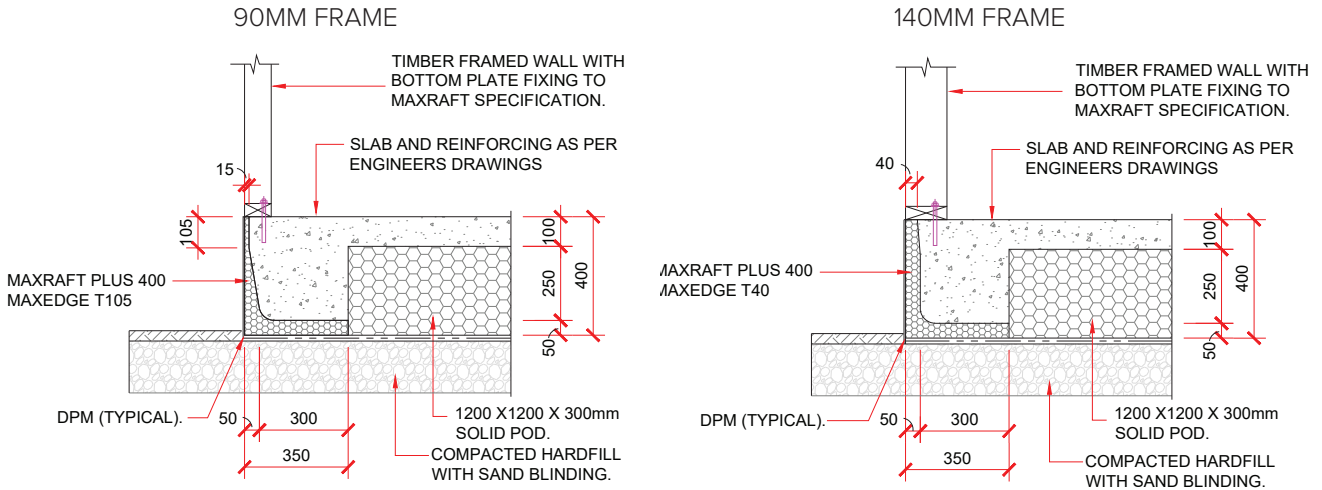

STANDARD HEIGHTS

320MM	340MM	400MM	420MM
--------------	--------------	--------------	--------------

Bespoke options available

R VALUE TABLE

	AREA / PERIMETER RATIO									
	1.6	1.8	2	2.2	2.4	2.6	2.8	3	3.6	4
MAXRaft Plus+ 320	2.38	2.54	2.7	2.86	3.02	3.18	3.35	3.51	3.81	4.02
MAXRaft Plus+ 400	2.44	2.62	2.81	2.97	3.13	3.29	3.46	3.62	3.95	4.17
MAXRaft Plus+ 320 Brick*	2.18	2.38	2.59	2.71	2.38	2.95	3.07	3.19	3.5	3.17
MAXRaft Plus+ 400 Brick*	2.11	2.29	2.47	2.6	2.73	2.86	2.99	3.12	3.57	3.87

* If brick cladding is to ground, please refer to the MAXSlab or MAXRaft R-Value details shown in above table. (Non-brick) alternative MAXEdge 90mm details available with angled bolt fixing.

* R-values are conservative and based on 90mm frames

** Higher R-values than shown in the above table can be achieved by adjusting the type of solid pod, please contact MAXRaft to increase your R-value if required.

SPECIFYING MAXRAFT

All MAXRaft Fully Insulated Foundations require an engineered design and PS1.

MAXRaft can complete your slab design in house by one of our trusted teams or you can use your preferred engineer.

Visit our website or contact us for a copy of our DWG & PDF Library of our standard details.

Save time and cost in the design process.

Another simple way to specify a MAXRaft product, you can engineer your own MAXRaft slab via the Specifi Platform.

MAXRaft Products are listed on Specifi, an online tool that saves time and enables you to control the timeframe of your slab design!

Specifi Benefits

- Quick turnaround within 72 hours
- Developed by experienced, professional New Zealand engineers
- No additional risk or liability to you when using Specifi
- Self site checks
- Easy to follow software
- Full support via phone or email



MAXRaft is Branz Appraised. Please see our website or contact the MAXRaft team for the more information.

UNDERFLOOR HEATING

New H1 requirements by climate zone for embedded UF heating.

Constuction R-Values (M2/K/W)					
ZONE 1	ZONE 2	ZONE 3	ZONE 4	ZONE 5	ZONE 6
2.5	2.5	2.5	2.8	3.0	3.0

MAXRaft products and embedded in-slab heating are a great combination.

Good ground & UF Heating

In most instances MAXSlab will meet the R2.5 to R3 requirement based on climate zone.

Soft soils & UF Heating

MAXRaft insulation is upgraded to MAXRaft Plus+ to meet the R-value requirements when underfloor heating is specified.

	Area / Perimeter Ratio									
	1.6	1.8	2	2.2	2.4	2.6	2.8	3	3.6	4
MAXSlab 300	2.77	2.99	3.22	3.38	3.54	3.7	3.86	4.02	4.49	4.81
MAXSlab 350	2.96	3.25	3.53	3.69	3.85	4.01	4.17	4.33	4.87	5.23
MAXSlab 400	2.89	3.17	3.45	3.65	3.84	4.04	4.23	4.43	4.92	5.25
MAXRaft 320 MAXRaft Plus+	2.38	2.54	2.7	2.86	3.02	3.18	3.35	3.51	3.81	4.02
MAXRaft 400 MAXRaft Plus+	2.44	2.62	2.81	2.97	3.13	3.29	3.46	3.62	3.95	4.17

Notes:

- We can adapt our MAXRaft products if and where required – especially where sites have soft soils and low A/P ratio.
- Underfloor heating pipes can be laid on the mesh or on the polystyrene.
- Where the pipes are installed on top of the mesh, typically the slab thickness and the mesh grade will be increased.





SUSTAINABILITY & RECYCLING

MAXRaft fully insulated foundation products are designed to be energy efficient, cost effective, and sustainably sourced. Our team continues to research new ways and technology to help provide the best foundation solutions, allowing you to live in a home with greater levels of comfort and increased health benefits for you and your family. We believe in building homes above the building standard with industry leading insulation.

Forward Thinking On Waste

All our designs includes a site specific panel plan prepared in house, it is sent to our manufacturers to pre-cut all the polystyrene materials in the factory. Cutting the materials in the factory means cleaner waste which is easy to contain and recycle. Once on-site the polystyrene materials are installed like a labelled jigsaw puzzle, reducing the need for on-site cutting.

MAXRaft EPS POLYSTYRENE IS 100% RECYCLABLE

All MAXRaft EPS polystyrene components contain approx. 15% recycled material. Once the polystyrene components have been installed on-site, any off-cuts can be returned to the manufacturer to be recycled into new material.

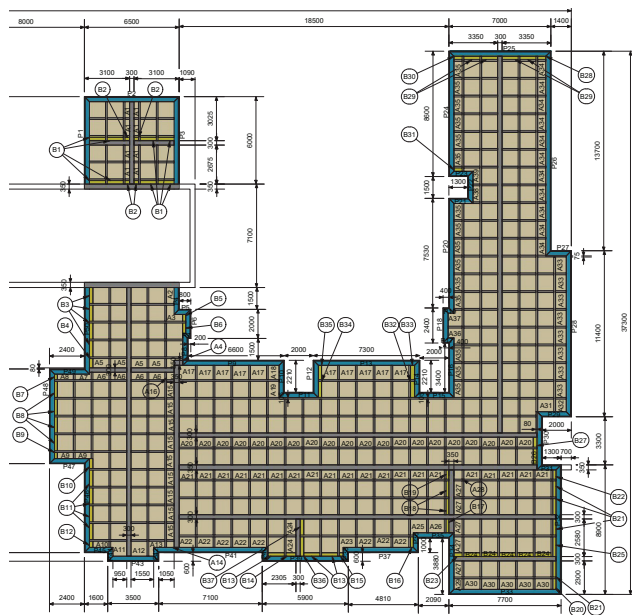
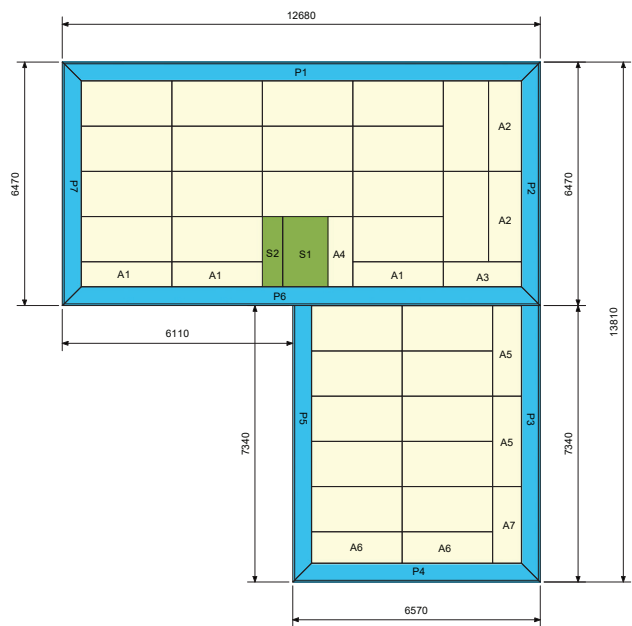

PANEL PLAN EXAMPLES

SUMMARY R-VALUE TABLE

		AREA / PERIMETER RATIO									
	Product	1.6	1.8	2	2.2	2.4	2.6	2.8	3	3.6	4
1	MAXSlab 300	2.42	2.64	2.85	3.01	3.17	3.32	3.48	3.64	4.03	4.28
2	MAXSlab 350	2.96	3.25	3.53	3.69	3.85	4.01	4.17	4.33	4.87	5.23
3	MAXSlab 400	2.89	3.17	3.45	3.65	3.84	4.04	4.23	4.43	4.92	5.25
4	MAXSlab 300 Brick Rebate	2.27	2.48	2.68	2.83	2.99	3.14	3.29	3.44	3.95	4.29
5	MAXRaft 320	1.71	1.82	1.92	2.01	2.09	2.18	2.27	2.35	2.59	2.75
6	MAXRaft 400	1.68	1.81	1.93	2.01	2.1	2.18	2.27	2.35	2.59	2.74
7	MAXRaft 320 Brick	1.62	1.73	1.85	1.93	2.02	2.11	2.2	2.29	2.53	2.69
8	MAXRaft 400 Brick	1.56	1.68	1.79	1.87	1.96	2.05	2.14	2.23	2.46	2.62
9	MAX85 305	1.46	1.54	1.62	1.7	1.77	1.85	1.92	2	2.21	2.36
10	MAX85 385	1.52	1.62	1.72	1.8	1.88	1.96	2.03	2.11	2.33	2.48
11	MAX85 305 Brick	1.3	1.39	1.47	1.55	1.62	1.7	1.78	1.85	2.06	2.21
12	MAX85 385 Brick	1.34	1.43	1.53	1.6	1.68	1.76	1.84	1.92	2.14	2.28
13	MAXRaft Plus+ 320 (50/50 POD)	2.38	2.54	2.7	2.86	3.02	3.18	3.35	3.51	3.81	4.02
14	MAXRaft Plus+ 400 (50/50 POD)	2.44	2.62	2.81	2.97	3.13	3.29	3.46	3.62	3.95	4.17
15	MAXRaft Plus+ 320 (SG POD)	2.5	2.67	2.84	3.01	3.19	3.36	3.53	3.7	4.03	4.25
16	MAXRaft Plus+ 400 (SG POD)	2.54	2.74	2.94	3.11	3.28	3.45	3.63	3.8	4.15	4.38
17	MAXRaft Plus+ 320 Brick (50/50 POD)	2.18	2.38	2.59	2.71	2.38	2.95	3.07	3.19	3.5	3.17
18	MAXRaft Plus+ 400 Brick (50/50 POD)	2.11	2.29	2.47	2.6	2.73	2.86	2.99	3.12	3.57	3.87

Product	Suitability
MAXSlab	Good Ground, TC1, 300KPA
MAXRaft 320	200KPA, M Class soils
MAXRaft 400	TC2, H Class Soils
MAX85 305	TC1, 200KPA, M Class soils
MAX85 385	TC2, H Class Soils
MAXRaft Plus+320	200KPA, M Class soils
MAXRaft Plus+400	TC2, H Class Soils



For more information or to get a quote:

PHONE: 0800 MAXRaft

0800 629 7238

EMAIL: [Hello@maxraft.co.nz](mailto>Hello@maxraft.co.nz)

quotes@maxraft.co.nz

WWW.MAXRaft.CO.NZ